

COOLEGE™

# LUMINOUS CEILINGS

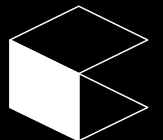

COOLEGE™

# EXPERIENCE THE FEELING OF THE OUTDOORS... INSIDE

Cooledge has combined its lighting expertise, technology, and innovation to emulate the canopy of light we call the sky by delivering a lineup of simple **FABRICated Luminaires** for virtually every ceiling, **FABRIColor** for high quality white plus dynamic color, as well as a range of **Specialty Illumination Solutions** for applications where an even larger scale is desirable.



ILLUMINATION BY NATURE



ILLUMINATION BY COOLEEDGE

“ I just wanted to reach out and say how awesome this luminous surface is... As an IT professional, I’m normally trapped in a room for hours on end perusing Google for answers to all of my problems. Since I can’t bring my desk outside, it’s nice to feel like I can bring the sun inside. It sounds crazy to express how much something as simple as lighting can affect how you feel. ”

Justin Bajkowski - Fielding’s Culinary Group



For most of human history, we lived outdoors under a large luminous surface...the sky. Not only have our eyes been adapted to illumination from the sky but also our minds and our bodies.

The sky is a “canopy of light” that creates an entire experience encompassing visual, emotional, and biological contributions to human well being.

People spend almost 90% of their time indoors: we are missing the natural canopy of light!

COOLEEDGE LUMINOUS CEILING BRING THE CANOPY OF LIGHT INDOORS

## IMMERSIVE ILLUMINATION



There has been a lot buzz about circadian lighting in the past few years but the reality is that there are still many unanswered questions about specific physiological benefits and the best way to implement solutions.

What is not in doubt, is that illumination does have a significant impact on how people experience indoor spaces. Studies have shown that the right lighting can positively impact a shopper’s emotional response, an office worker’s productivity, or a long

term care resident’s health. A common theme is the need to create environments that have the ability to adapt to the needs of the users including emulating the natural canopy of light that we are missing 90% of the time.

In order to achieve this goal, the ambient lighting must deliver all of the characteristics of “immersive illumination” which is comfortable, uniform, flicker free, tunable and dimmable light delivered on the scale of nature.

IMMERSIVE ILLUMINATION ISN'T SOMETHING YOU MEASURE WITH A LIGHT METER... IT'S AN EXPERIENCE



**IMMERSIVE ILLUMINATION REQUIRES HIGH QUALITY LIGHTING**

Optical and spectral characteristics of LEDs are altered when the light they emit passes through a diffuser. Cooledge provides LM-79 light quality data for the actual light output from fabric diffuser not just the LEDs, including:

- ✔ Color Rendering
- ✔ R-Values
- ✔ TM-30-15
- ✔ Spectral Power Distribution
- ✔ Chromaticity

“ Diffuse general lighting ensures a subjective sense of well-being. ”

Prof. Jan Ejhad, Royal Institute of Technology in Stockholm;  
Prof. Dr. Roland Greule, HAW Hamburg; Markus Felsch, Felsch Lighting Design

# A COMPLETE PORTFOLIO OF PRODUCTS FOR LUMINOUS CEILINGS

Cooledge offers a full range of products to deliver luminous ceilings that create immersive illumination experiences that bring the outdoors... inside.



## FABRICOLOR

Do you have a space that serves a variety of functions and users needs? Do you require high quality functional illumination for working or shopping but also rich immersive color or vibrant dynamic scenes to create an emotional experience or simply have some fun? FABRIColor delivers all of these possibilities and more...

- No Specialty Installers Required
- Standard sizes up to a maximum of nom. 6' x 9' (1.8m x 2.7m)
- Flux Levels: High
- Suspended
- Surface Mount
- Grid (T-bar)



## FABRICATED LUMINAIRES

Deliver the immersive illumination of luminous ceilings in simple, familiar formats that can be ordered and delivered to meet almost any schedule. Large-scale luminaires bring the feeling of the outdoors inside by creating artificial skylights in a grid ceiling or filling an open concept space with canopies of light that can also absorb sound, in some cases replacing other acoustic materials.

- No Specialty Installers Required
- Standard sizes up to a maximum of nom. 6' x 9' (1.8m x 2.7m)
- Flux Levels: High, Medium
- Suspended
- Surface Mount
- Recessed (Drywall/Plaster)
- Grid (T-bar)

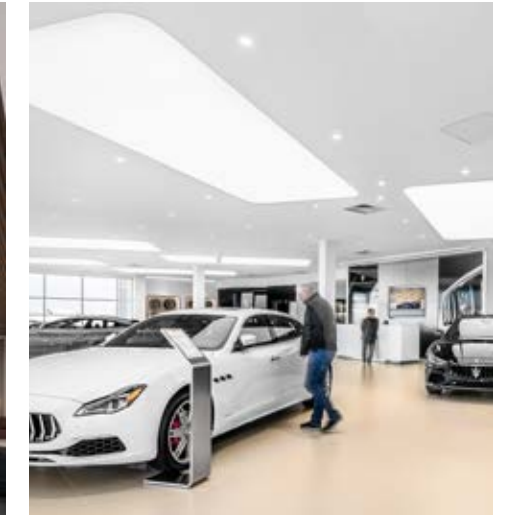

## SPECIALTY ILLUMINATION SOLUTIONS

To fully emulate the outdoor experience, scale becomes the key factor. For large area luminous ceilings, Cooledge offers a range of illumination solutions that are assembled on-site by trained installers to create immersive environments on a scale worthy of nature.

- Specialty Installers Required
- Custom sizes to a maximum of 15.5ft x 161ft (4.7m x 49m)
- Flux Levels: High, Medium, Low
- Suspended
- Surface Mount
- Flush Mount

# FABRICOLOR

ONE SPACE... MANY FUNCTIONS... INFINITE POSSIBILITIES

Do you have a space that serves a variety of functions and users needs? Do you require high quality functional illumination for working or shopping but also rich immersive color or vibrant dynamic scenes to create an emotional experience or simply have some fun? FABRIColor delivers all of these possibilities and more...



HIGH QUALITY FUNCTIONAL ILLUMINATION



IMMERSIVE COLOR



DYNAMIC SCENES

## IMMERSIVE ILLUMINATION

**PLUS** DYNAMIC COLOR = IMMERSIVE COLOR

FABRIColor adds RGB capability to Cooledge's superior white light illumination and acoustic performance to deliver W+RGB products that are unlike anything you've seen before.

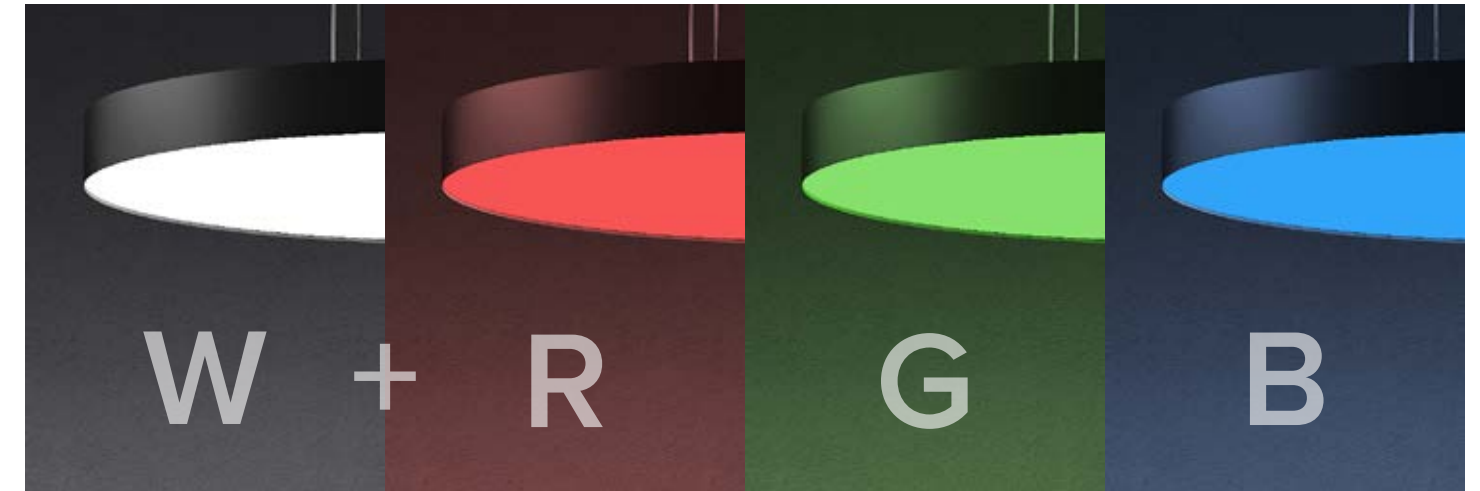

## SUPERIOR QUALITY GENERAL ILLUMINATION

- Correlated Color Temperature (CCT) = 3500K
- CRI (Ra) – White = 94
- R9 = 64

## IMMERSIVE COLOR

- DMX compatible (8-bit & 16-bit)

## LARGE SCALE FORMS

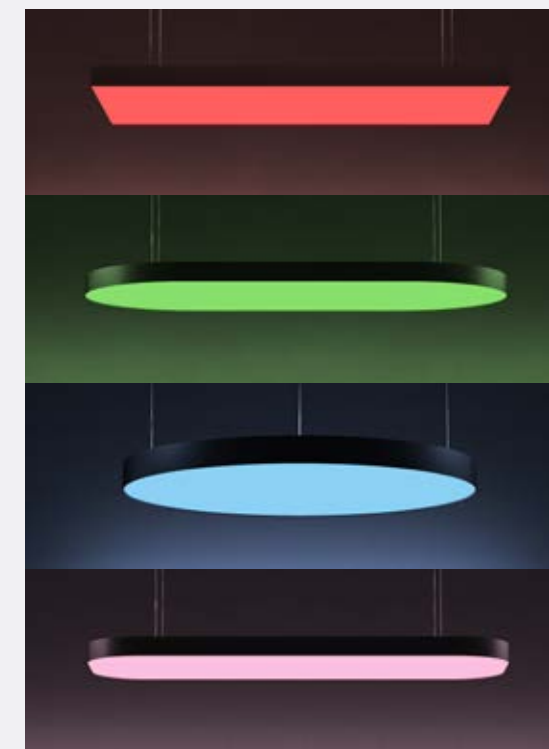

FABRIColor combines large scale forms, immersive color, and acoustic performance in a single solution that is unique to the world of architectural lighting.

### RECTANGLES

- RXS (4'x4' / 1200mm x 1200mm)
- RS (4'x6' / 1200mm x 1800mm)
- RM (4'x8' / 1200mm x 2400mm)
- RL (6'x6' / 1800mm x 1800mm)
- RXL (6'x8' / 1800mm x 2400mm)

### BULLNOSE

- BNM (4'x8' / 1200mm x 2400mm)

### CIRCLES

- CS (4' / 1200mm diameter)
- CL (6' / 1800mm diameter)

### CURVED CORNERS

- CCL (6'x9' / 1800mm x 2700mm)

\*Sizes shown are nominal. For exact dimensions, refer to the product specifications.

# FABRICATED LUMINAIRES

## IMMERSIVE ILLUMINATION MEETS FORM & FUNCTION

FABRICated Luminaires are offered in a wide range of forms, sizes and available in every common mounting configuration to ensure compatibility with standard designs.

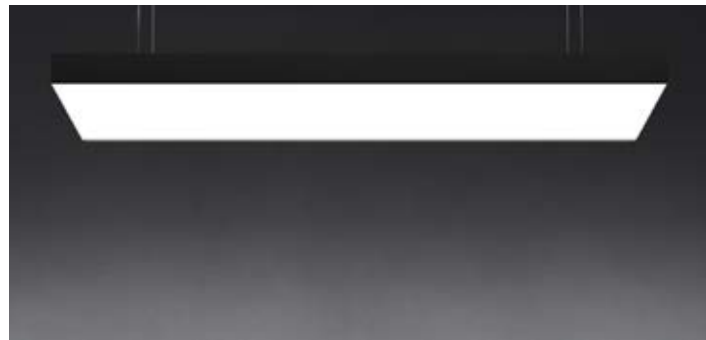

### RECTANGLES

The traditional shape of the built environment.

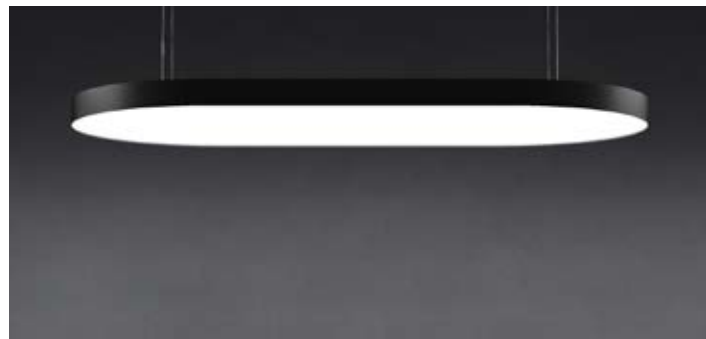

### BULLNOSE

Embrace an entirely new aesthetic. Bullnose forms combine straight sides with full radius curved ends to create a compelling look on a scale not seen before in luminaires.



### CIRCLES

Change the visual experience of an entire space simply by using large scale circles instead of traditional lines and rectangles.



### CURVED CORNERS

Soften the edges by incorporating curved corners on FABRICated Luminaires that fully deliver the immersive experience of illumination.

## REVOLUTIONARY AND SIMPLE

FABRICated Luminaires are revolutionary because they deliver illumination on the scale of nature, absorb sound (more later), and bring a unique look and feel to a space. But what may be even more revolutionary is that they do all of this while at the same time remaining simple and familiar to everyone.

### SIMPLE TO UNDERSTAND

- ✓ They're luminaires...but bigger and better

### SIMPLE TO SPECIFY

- ✓ Standard sizes
- ✓ Standard options
- ✓ Standard prices
- ✓ Standard lead times

### SIMPLE TO ORDER

- ✓ Short leadtimes

### SIMPLE TO INSTALL

- ✓ Ready-out-of-the-box
- ✓ No specialty ceiling contractors required
- ✓ Industry standard mounting methods that are easily understood by electrical installers



### POWER & CONTROL TRAY

Mounts directly to the luminaire or in a convenient remote location



### INDUSTRY STANDARD MOUNTING METHODS

Check out our Installation Guide Videos at [www.cooledgelighting.com/fabricated-luminaires](http://www.cooledgelighting.com/fabricated-luminaires)



# FABRICATED LUMINAIRES

## MOUNTING OPTIONS

Cooledge FABRICated Luminares use simple, industry-standard mounting methods that are familiar to electrical installers across the globe.

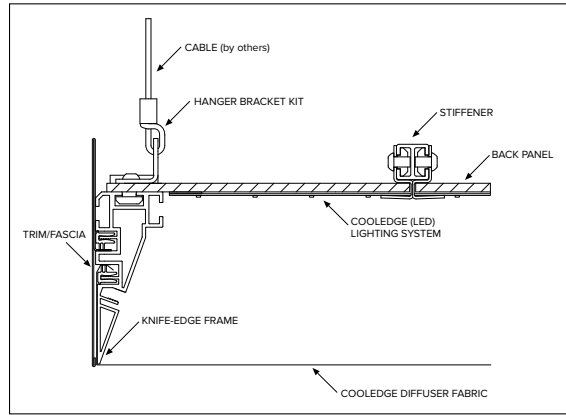

SUSPENDED (CABLE OPTION)

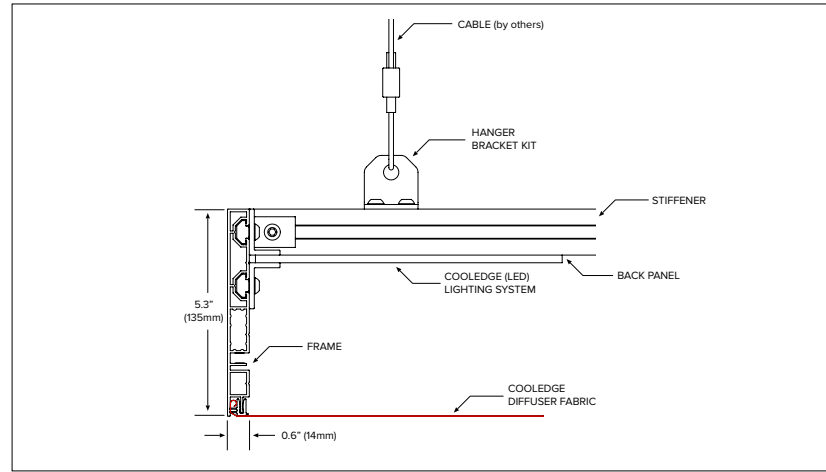

SUSPENDED (ROUNDS)

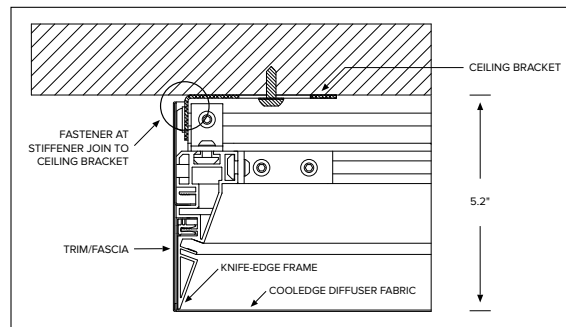

SURFACE MOUNT

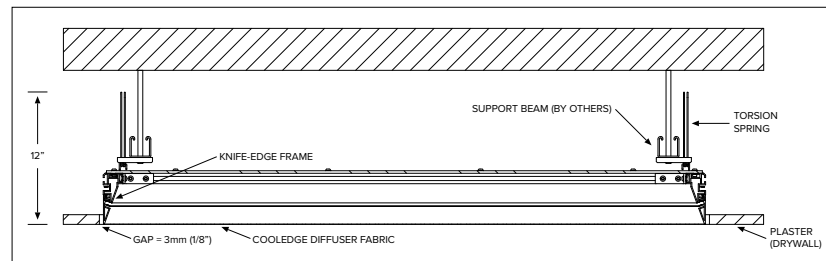

RECESSED

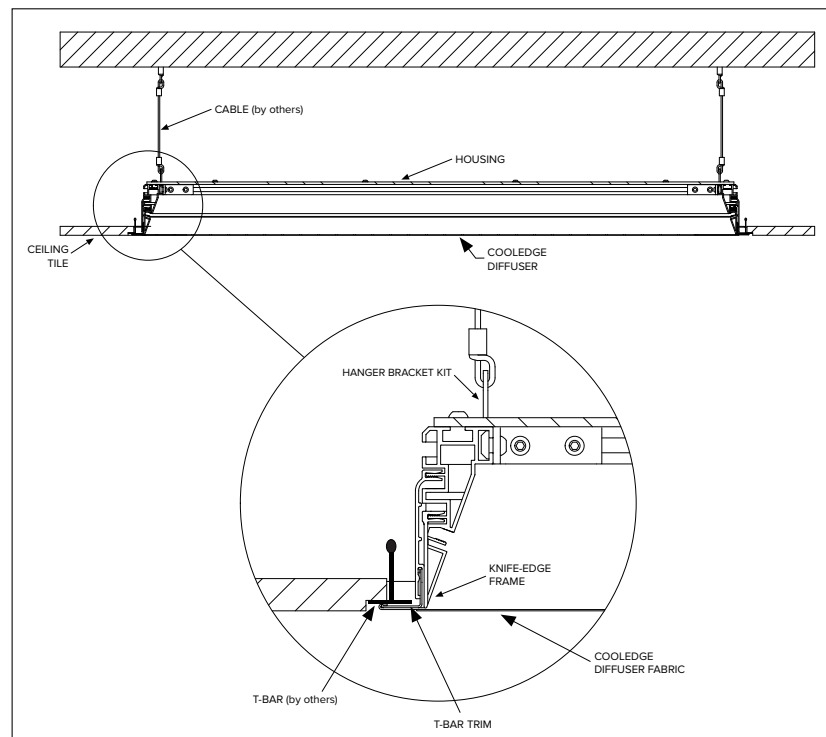

GRID (T-BAR)

## A COUPLE OF THINGS ABOUT INSTALLATION

- ✓ Optical and spectral characteristics of LEDs are altered when the light they emit passes through a diffuser. Cooledge FABRICated Luminares are shipped with a protective plastic cover >> during installation this cover should remain in place until the installation instructions call for removal.
- ✓ After removal of the protective plastic, clean cloth gloves must be worn to handle the luminaire.



# SPECIALTY ILLUMINATION SOLUTIONS

To fully emulate the outdoor experience, scale becomes the key factor. For large area luminous ceilings, Cooledge offers a range of illumination solutions that are assembled on-site by trained installers to create immersive environments on a scale worthy of nature.

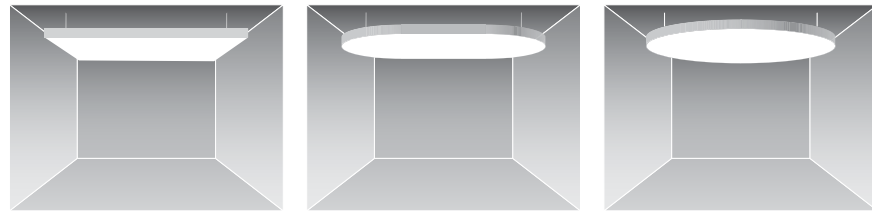

## SUSPENDED

Large scale solutions assembled on-site and hung from cable or threaded rods.

*Rectangles feature Infinity Edge Technology*

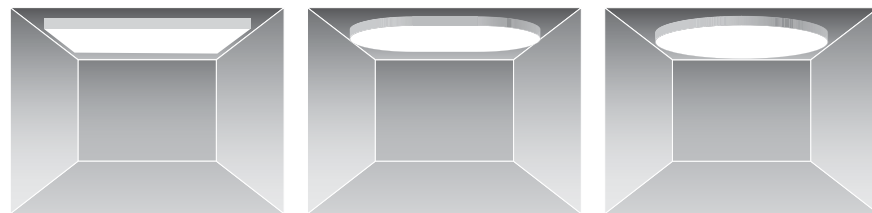

## SURFACE MOUNT

Large scale solutions assembled on-site to maximize the feeling of openness or to blend with the ceiling finish.

*Rectangles feature Infinity Edge Technology*

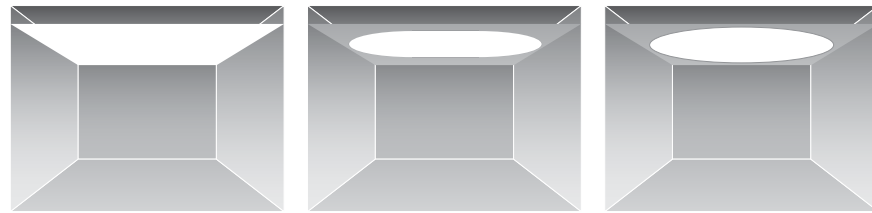

## FLUSH MOUNT

Solutions are mounted from wall-to-wall across a ceiling cavity to deliver continuous immersive illumination.

*Curves and Round Shapes Available*



## MOUNTING DETAILS

Specialty Illumination Solutions are installed by Cooledge certified installers using industry-standard mounting methods that are easily incorporated into ceiling designs.

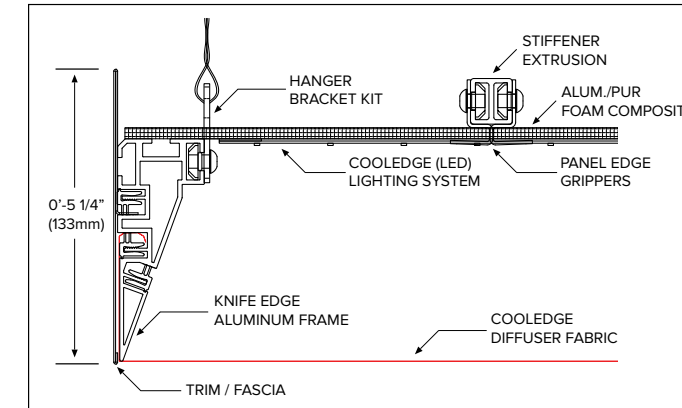

SUSPENDED - RECTANGLE INFINITY EDGE (CABLE OPTION)

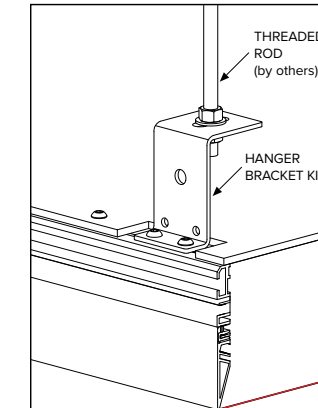

SUSPENDED (THREADED ROD OPTION)

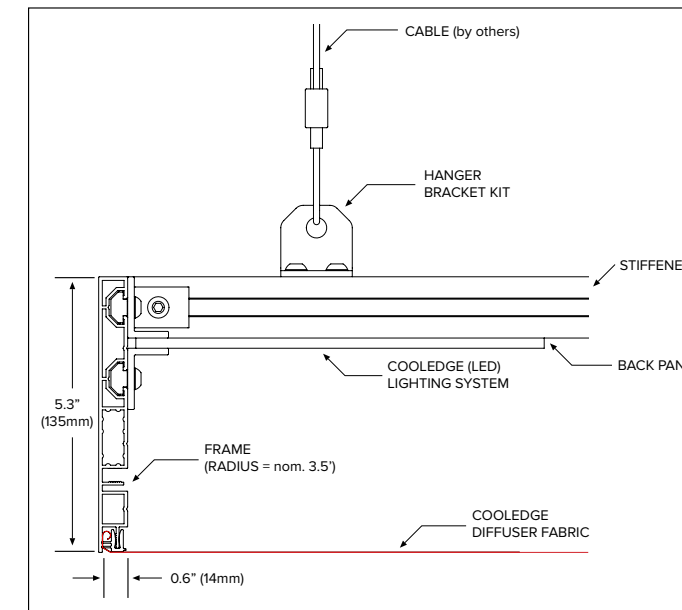

SUSPENDED - CURVED/ROUND/CIRCLE (CABLE OPTION)

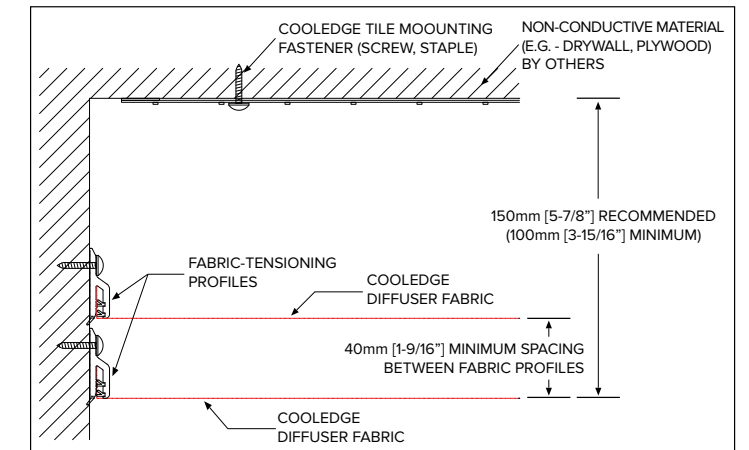

FLUSH MOUNT

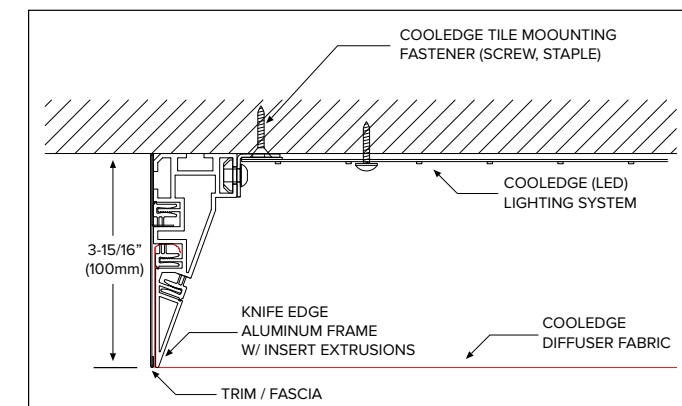

SURFACE MOUNT - RECTANGLE INFINITY EDGE

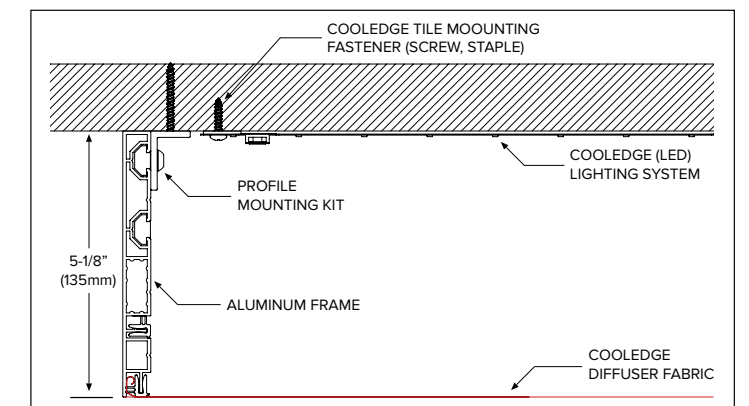

SURFACE MOUNT - CURVED/ROUND/CIRCLE

# INTRODUCING THE “INFINITY EDGE”

Cooledge asked specifiers what is the most important design feature they wanted to see in a ceiling luminaire. The Overwhelming #1 Response: a clean knife-edge without shadows or dark spots.



A PROPRIETARY DESIGN DELIVERS EVEN ILLUMINATION FROM EDGE TO EDGE OF EVERY FABRICATED LUMINAIRE.



## TUNABLE WHITE: CONTROL ON THE SCALE OF NATURE

CREATING AN ENVIRONMENT THAT EMULATES AN OUTDOOR EXPERIENCE REQUIRES THAT THE AMBIENT ILLUMINATION CHANGE TO MATCH THE TIME OF DAY.

MORNING



MID-DAY



EVENING



## C-TUNE TECHNOLOGY

Cooledge Luminous Ceiling products incorporate our proprietary C-Tune technology to enable tunable white for projects where the cost or complexity of alternative products makes their use impossible.

C-Tune simplifies wiring and employs the same components as our static color temperature products to significantly increase affordability, allowing you the flexibility to create multiple user experiences in the same space without breaking your budget.

Cooledge technology enables deep dimming at any chosen CCT within the tunable range.

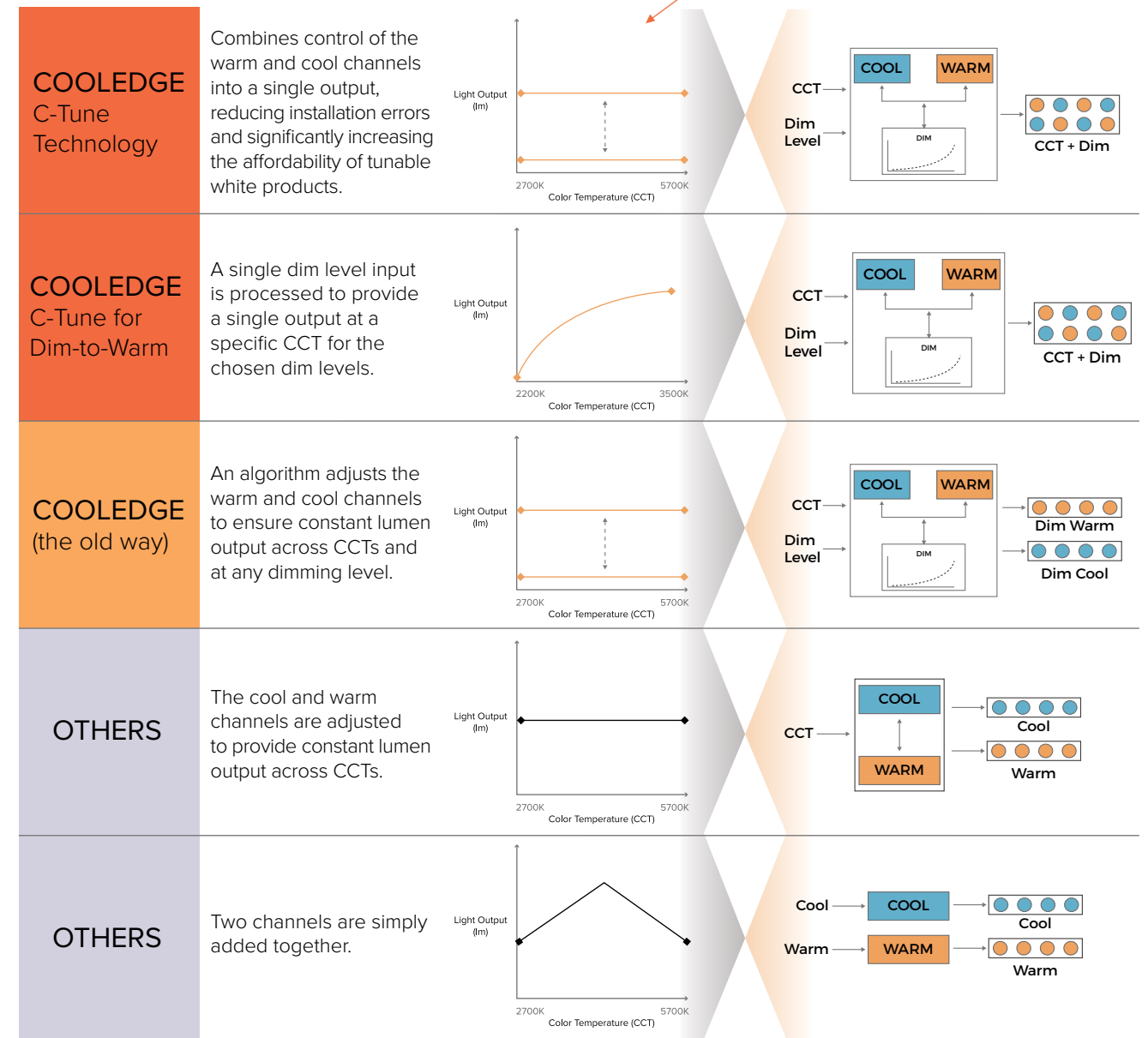



# A NIGHTMARE OF NOISE: LUMINOUS CEILINGS CAN HELP

APPROXIMATELY 80 PERCENT OF OFFICE WORKERS BELIEVE THAT THEIR PRODUCTIVITY WOULD INCREASE IF THEIR WORKING ENVIRONMENT WAS MORE ACOUSTICALLY PRIVATE.\*



The desire for “open concept” spaces combined with the trend toward using stone or tile for floors for durability and easy maintenance that results in low sound absorption and higher sound reflectance is a “nightmare of noise” in the making for offices, retail stores, and public areas.

In open spaces, an effective method of reducing sound pollution is to suspend acoustic clouds or baffles from the ceiling.

Suspended FABRICated Luminaires can replace acoustic clouds AND provide illumination in a single product saving the

cost of the acoustic materials and avoiding the visual clutter created when trying to combine luminaires for general lighting in the same space as the sound absorbing fixtures.

All **Cooledge Luminous Ceilings** products have sound absorption properties that are superior to most materials used for interior spaces.

Most standard ceiling luminaires have no sound absorption capability and hence contribute to the “nightmare of noise”.

\*American Society of Interior Designers; Armstrong World Industries, Inc.; DynaSound, Inc.; Milliken and Co.; Steelcase, Inc, 2005

## NOISE REDUCTION COEFFICIENT (NRC)

The Noise Reduction Coefficient is a value used to characterize the ability of a material or object to absorb sound. It represents the average absorption for 4 sound frequencies typically encountered in the range of normal speech. A value of 0 means that all sound will be reflected, 0.5 means 50% of the sound is

absorbed and 50% is reflected, while 1.0 means 100% of the sound is absorbed. In some regions, it is more common to refer to the ISO classification which identifies a specific range of sound absorption values using letters, with “Class A” being the best.

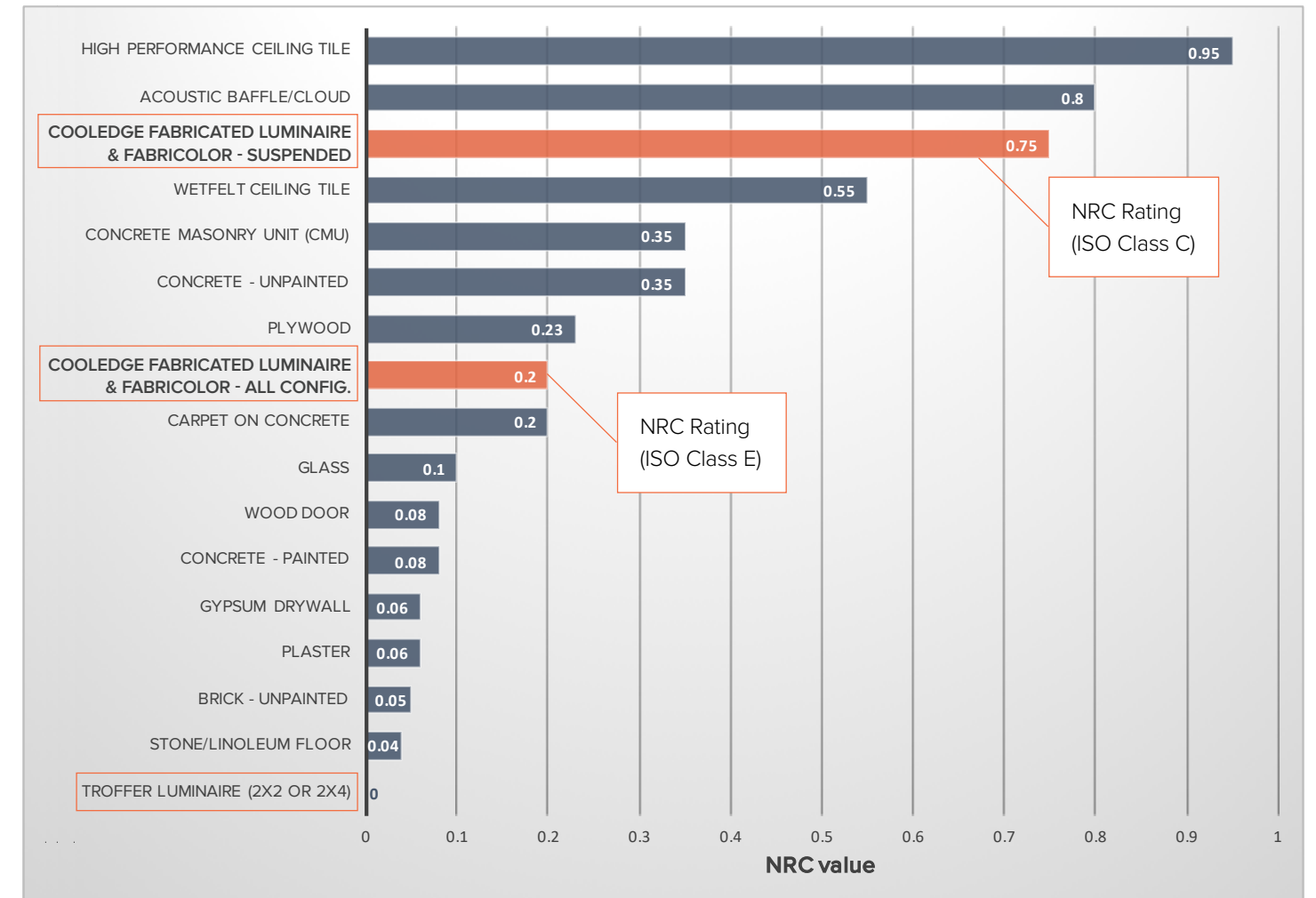

Compiled by Cooledge Lighting from multiple sources

**FABRICated Luminaires** provide better acoustic performance than many typical building materials. For open concept spaces,

Suspended models may be ordered with an NRC value (0.75) that delivers similar performance to acoustic ceiling materials.



LumiScapes by Cooledge is a portfolio of standard products that deliver the unique immersive illumination experience of the outdoors at price levels that enable their use in everyday spaces.



### FABRICORE

FABRICore is a large area acoustic LED luminaire available for general area illumination applications that combines immersive illumination with acoustic performance to fit any budget.

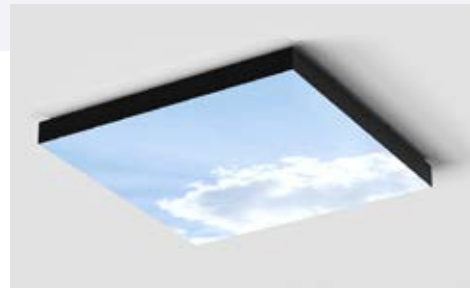

### FABRICLOUD

FABRICloud is a large area acoustic LED luminaire that quite literally brings the feeling of the outdoors to interior spaces with vibrant skiescapes. Capture a piece of the sky with a single luminaire or create an expansive scenic canopy of natural illumination by grouping luminaires together in preset scenes, all without breaking the budget.

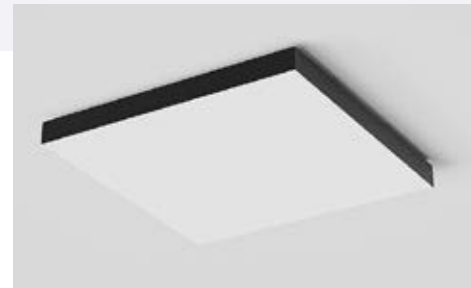

### FABRIQUIET

FABRIQuiet is a sound absorbing panel that is the perfect acoustic complement to FABRICore, delivering the same exceptional noise reduction capability with matching aesthetics to ensure design continuity throughout your space.

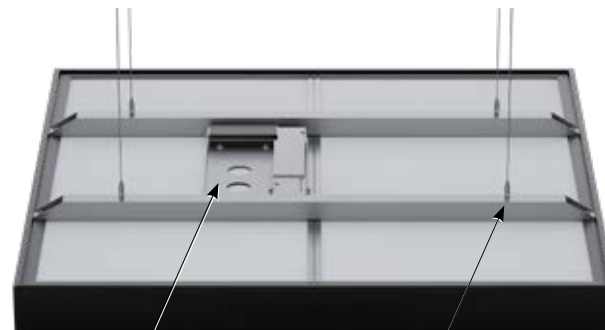
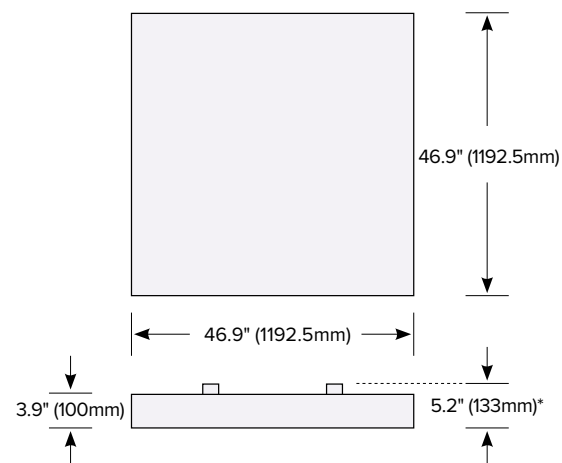

Power & Control tray\*  
(may be removed and mounted to ceiling)  
\*except FABRIQuiet

Suspended Mounting Option (LACC-SP-K)

#### CERTIFICATION



## WE CREATE LUMINOUS CEILINGS,

AN INTERACTION BETWEEN LIGHT AND ARCHITECTURAL DIFFUSION MATERIALS THAT BRINGS THE FEELING OF THE OUTDOORS... INSIDE.

For more information visit: [www.cooledgelighting.com](http://www.cooledgelighting.com)



110-13551 Commerce Parkway  
Richmond, BC, Canada V6V 2L1  
+1 604 273 2665

201 Jones Road, 2nd Floor  
Waltham, MA 02451  
+1 781 899 0317

Toll Free: +1 844 455 4448

[www.cooledgelighting.com](http://www.cooledgelighting.com)

**Photography Credits:**

Front cover: Forest City Realty Trust (Cleveland, OH); Copyright: Matthew Carbone, Photographer LLC

Page 2 (left): Courtesy of Velux

Page 2 (right): 500 W Monroe (Chicago, IL); Hedrich Blessing

Pages 5 & 10: 1 Conagra Drive (Omaha, NB); Tom Kessler Photography

Page 9: 833 Chestnut (Philadelphia, PA); Francis Dzikowski Photography

